

**NOTE:** USE 40 CONCRETE COVER THROUGHOUT.

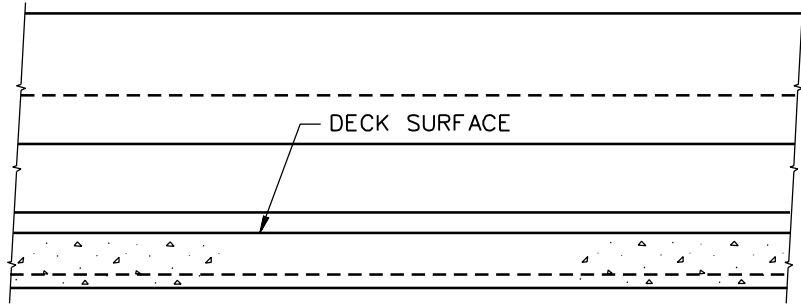

**ELEVATION**

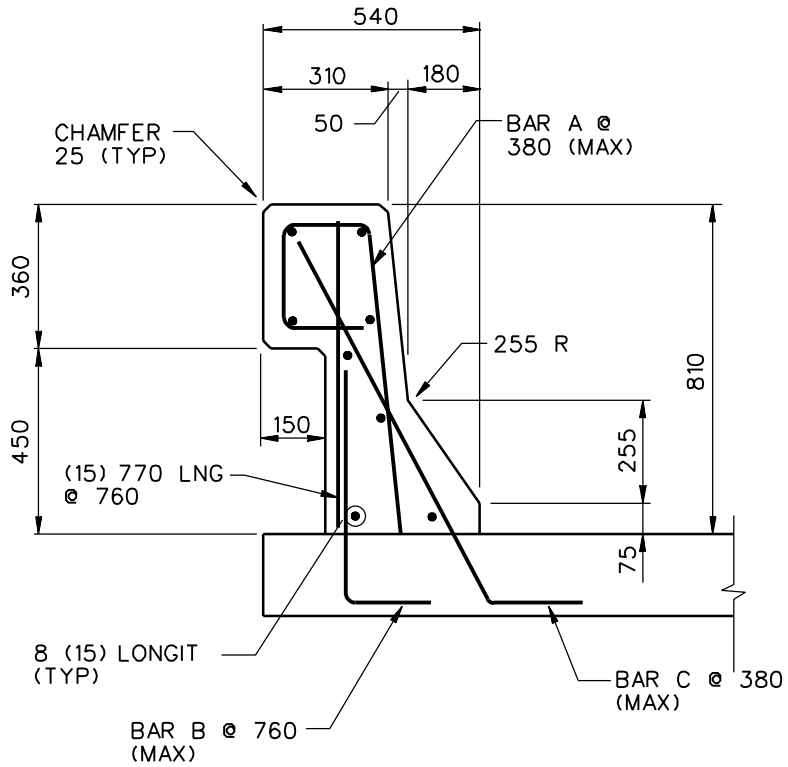

**SECTION**

1994

**SAFETY-SHAPED CONCRETE BRIDGE RAILING**

**SBC06b**

SHEET NO.

REF. NO.

1 of 4

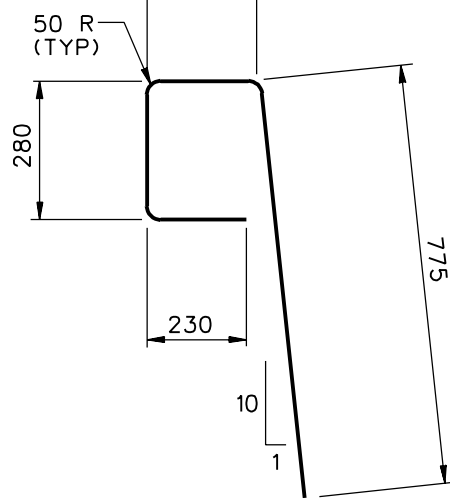

**BAR A (15)**

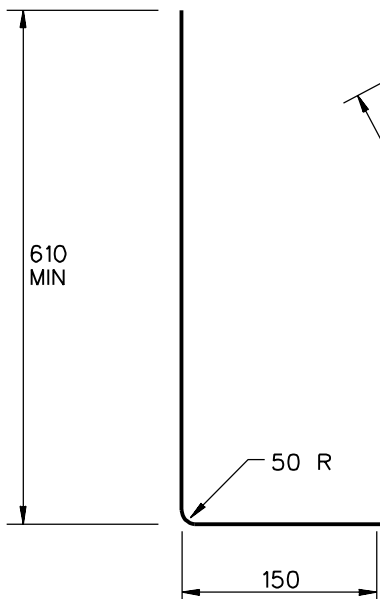

**BAR B (15)**

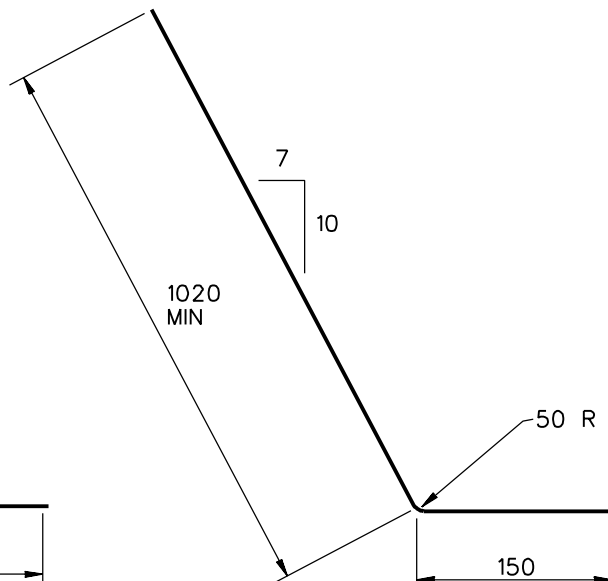

**BAR C (15)**

1994

**SAFETY-SHAPED CONCRETE BRIDGE RAILING**

**SBC06b**

SHEET NO.

REF. NO.

3 of 4